



WE INNOVATE EVERY DAY.
e-one.com

COMMERCIAL PUMPER



SPECIFICATIONS

QUALITY. PERFORMANCE. FLEXIBILITY.

Manufactured by the same skilled technicians and engineers who design E-ONE custom products, E-ONE commercial pumpers offer the perfect combination of Quality, Performance and Flexibility to meet your department's operational and budgetary needs. Quality - commercial pumpers are fully engineered for prompt delivery, easy service and reduced cost over the life of your department's apparatus. Performance - E-ONE partners with the most reliable commercial chassis manufacturers in the industry to pair with our proven extruded aluminum body design. Flexibility - commercial pumpers offer a variety of storage options, compartment configurations, uniquely designed shelves, trays and pull-out boards to keep your ladders and equipment clean and protected from the elements as well as easy to access. E-ONE commercial pumpers -the Quality, Performance and Flexibility you expect from every member of your team.

OUR VEHICLES CONNECT AND PROTECT
PEOPLE AROUND THE WORLD EVERY DAY.



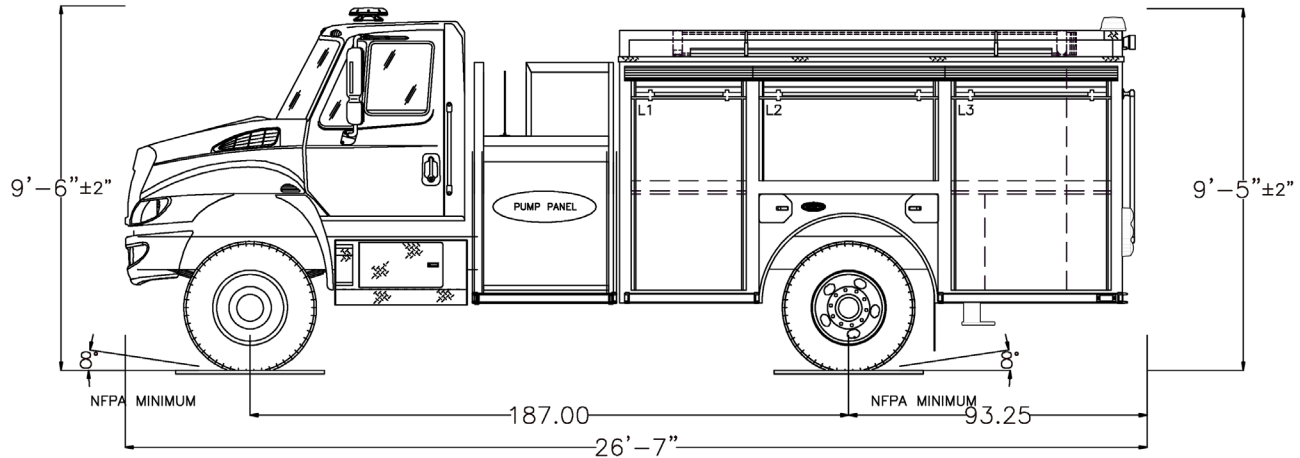

CHASSIS

- Freightliner® or International® chassis
- Up to 450 HP Engine
- Two-door, two-door extended, or four-door cabs
- Air conditioning
- 50-gallon aluminum fuel tank
- Allison transmission with touch-button shifter
- Two-wheel or four-wheel drive

BODY

- Body available in 3/16" extruded aluminum or stainless steel
- Optional low hose bed and a variety of speed lay configurations for easy access from the ground
- Pumper options include: 1/2, 3/4 or full-height driver side and/or officer side compartments; enhanced-extended rear and side compartments for up to 23 cu. ft. of additional compartment space; and up to six NFPA ladder/equipment storage options
- Rescue pumper options include: full-height, full-depth driver side and/ or officer side compartments; enhanced-extended rear compartments; rooftop compartments; and ladder storage options such as electric drop down racks, hydraulic overhead racks, high capacity two-arm ladder racks or enclosed tunnel storage
- Additional options include: hinged or roll-up doors, hydraulic or engine driven generator, adjustable shelves, roll-out trays, tool boards, SCBA storage, aluminum or vinyl hose bed covers

FIRE PACKAGE

- Hale®, Waterous®, or Darley® pumps
- Up to 2000 GPM
- Side-Mount or Top-Mount pump controls
- 530 to 1530 gallon tank capacity; integral foam cells available
- Optional foam systems, direct injection, CAFS and around the pump (ATP)
- Customizable discharge and preconnects to meet departments needs
- Side, front or rear intakes

ELECTRICAL

- Aluminum center console providing easy access to mission critical control
- Multiplex electrical system provides increased feature capability and improved diagnostics
- Available color vista display
- Whelen® optical and audible warning packages standard, others optional
- Fixed and pole mounted scene lights
- 12-V and 120-V outlets